



IMPORTANT:

Currently we have 2 different styles of Anchor Kits. A single strap kit and a cable tie kit. You may receive either one depending on your supplier. Both kits are pictured below highlighting some extra important instructions. How to install directions pictured right.

Single Strap Anchor Kit



IMPORTANT

- a. Make sure strap is doubled over & you are screwing into the eyelet side, then pierce the strap, into the wall.
- b. It is essential that anti-tilt strap is screwed into a stud in the wall. Stud can be located via a stud finder - seek professional advice.

Cable Tie Anchor Kit

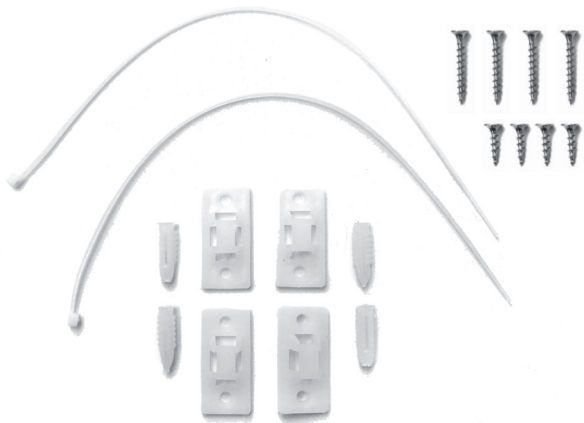

For extra strength we recommend you anchor your kit to a stud in the wall & align.

SINGLE STRAP ANCHOR KIT

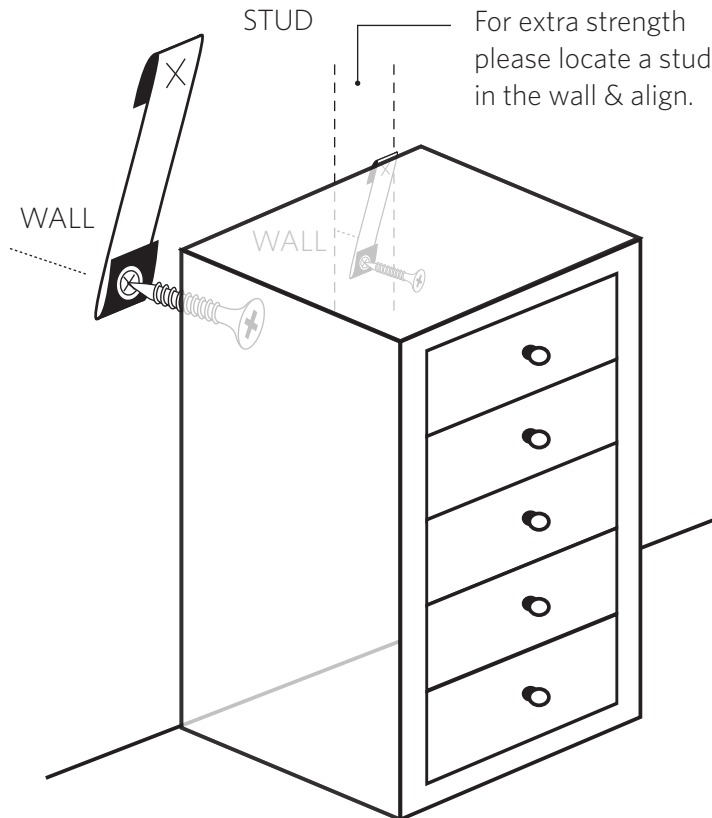
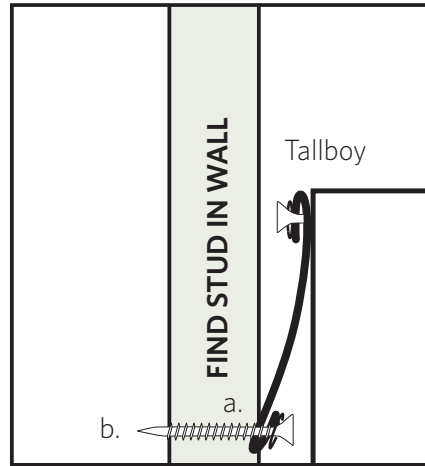

CABLE TIE ANCHOR KIT

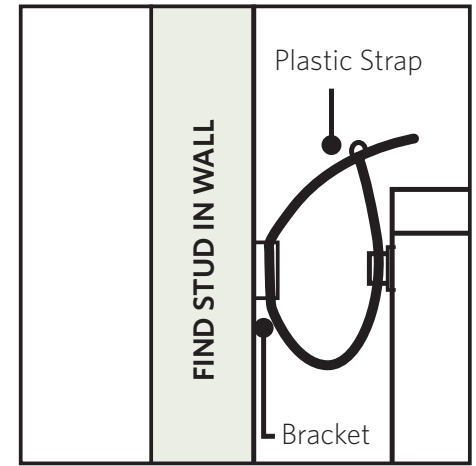

For extra strength please locate a stud in the wall & align.

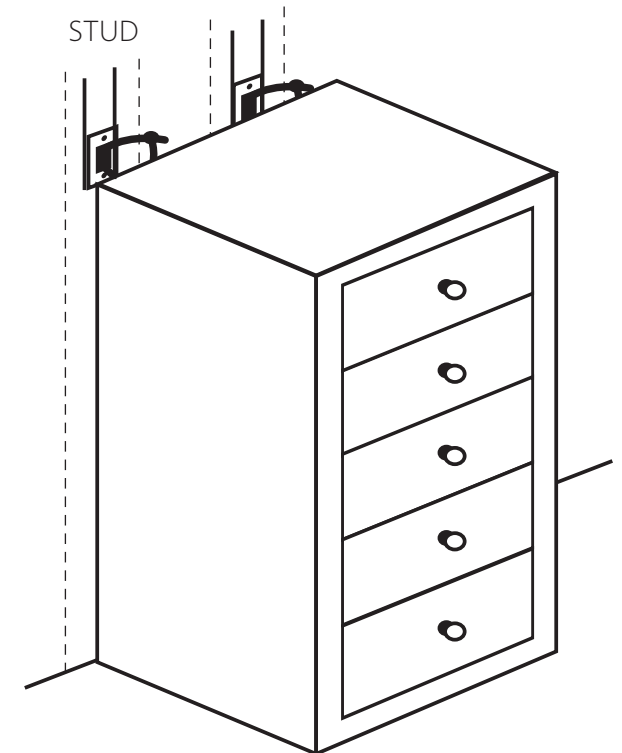



TIPS



SAFETY



MORE INFO

TIPS TO PREVENT THE INCIDENCE OF FURNITURE TIP OVER:

- Install tip-over restraint provided.
- Place heaviest items in the lower drawers.
- Unless specifically designed to accommodate, do not set TVs or other heavy objects on top of this product.
- Never allow children to climb or hang on drawers, doors or shelves.
- Never open more than one drawer at a time (OR)
- Do not defeat or remove the drawer interlock system.
- Use of tip-over restraints may only reduce, but not eliminate the risk of tip-over.

Note: Children like climbing on things, especially if there is something up high they want. Household furniture like bookshelves and entertainment units can be attractive to climb. So too, furniture like tallboys where pulled-out drawers act as stairs for climbing.

CAUTION!

IT IS IMPORTANT TO UNDERSTAND
- SOME FURNITURE IF TIPPED OVER,
CAN CAUSE SERIOUS OR FATAL INJURY.

IMPORTANT: To prevent your furniture from tilting forward it is recommended that you:

1. Avoid fully opening all drawers at the same time
2. Avoid small children from climbing onto drawers
3. Securely attach the anti tilt straps provided to your wall

For your safety when attaching the anti tilt straps;

1. Check for any electrical wires or plumbing inside the wall before drilling any holes (if you are unsure please seek professional advice)
2. Walls are constructed from different materials eg; masonry (solid brick) or plaster board lined cavity walls (hollow). It is important that you use the appropriate wall fixings for your wall type (your local hardware store will have the necessary drills and fixings and can offer advice if needed).

CONTACT US

Customer safety is paramount to Focus On Furniture – so we are always on hand to discuss any concerns or offer any additional advice.

Please call our customer service team on 9238 6900 or custserv@focusonfurniture.com.au

Focus On Furniture are committed to ensuring absolute compliance of the recent national toppling furniture strategy.

The Australian Competition and Consumer Commission recently undertook research into consumer awareness of furniture hazards in 2015 as a result of the increased incidents of child fatalities caused by toppling furniture.

If tipped over, the weight of the unit and its contents become a lethal force.

However, these injuries and fatalities can be prevented with just a little effort.

For furniture that is prone to toppling, it is important that it is secured to a wall. Anchor kits are provided with all our tallboy furniture, including easy step guide on how to use the systems provided.

It is essential you install anchor device provided with your item, carefully following assembly instructions to avoid serious toppling injury.

Our staff will happily offer you any assistance. For more information please go to:

<https://www.productsafety.gov.au/news/toppling-furniture-and-televisions-anchor-them-and-save-a-child-s-life>

<https://www.anchorit.gov/how-to-anchor-it/>